

TERMINALES TUBULARES EN COBRE A COMPRESIÓN

Apriete por punzonado

CONEXIONES ELECTRICAS, S.A.



Commercial cable lugs - Crimping by punching
Cosses de cuivre - Sertissage per poinçonnage

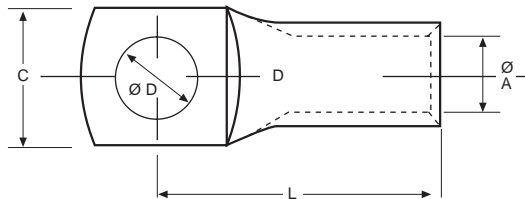

Material:
SECU Y SFCU S/DIN 1787-73

Acabado:
ESTAÑADO, TINNED, ETAMÉ

CABLE		Ø	Ø	Ø	L	HERRAMIENTA Tool / Outil	REF.	CABLE		Ø	Ø	Ø	L	HERRAMIENTA Tool / Outil	REF.	
Norm.	Flex.	A	C	D				Norm.	Flex.	A	C	D				
1,5	1	1,5	6,3	5,3	11,95	A6, TP3	15 - 30	10	6	4,5	14,25	8,5	23,75	T50 y TP3	43 - 80	
1,5	1	1,5	8	4,3	13,6		15 - 45	10	6	4,5	16	10,5	27,75		43 - 100	
1,5	1	1,5	8	5,3	13,6		15 - 55	10	6	4,5	18,5	12,5	30		43 - 120	
2,5	1,5	2,5	6,8	3,2	14		20 - 30	10	6	5	10	4,3	19,8		50 - 40	
2,5	1,5	2,5	8	4,2	14		20 - 45	10	6	5	10	5,3	20,3		50 - 50	
2,5	1,5	2,5	8	5,2	14		20 - 50	10	6	5	12,5	6,5	22,7		50 - 60	
4	2,5	3	8	4,5	15,5		30 - 40	10	6	5	14,25	8,5	23,8		50 - 80	
4	2,5	3	8	5,5	15,5		30 - 50	10	6	5	16	10,5	27,75		50 - 100	
4	2,5	3	8	6,5	17		30 - 60	10	6	5	18,5	12,5	31,5		50 - 120	
6	4	4	9	4,3	18,5		40 - 40	16	10	5,5	12	5,3	21,8		T50 y TP5	56 - 50
6	4	4	9	5,3	18,5		40 - 50	16	10	5,5	12	6,5	22,3			56 - 60
6	4	4	11,5	6,5	20		40 - 60	16	10	5,5	14,25	8,5	24,3			56 - 80
6	4	4	14,25	8,5	21,5		40 - 80	16	10	5,5	14,25	8,5	24,3			56 - 100
10	6	4,5	9	5,3	19,8	43 - 50	16	10	5,5	18,5	12,5	33	56 - 120			
10	6	4,5	13	6,5	23,3	43 - 60	16	10	6	12	5,3	22,8	60 - 50			

TERMINALES TUBULARES EN COBRE A COMPRESIÓN

Apriete por punzonado

CONEXIONES ELECTRICAS, S.A.



Commercial cable lugs - Crimping by punching
Cosses de cuivre - Sertissage per poinçonnage

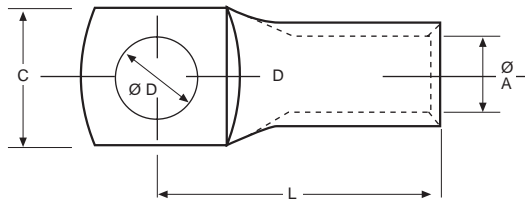

Material:
SECU Y SFCU S/DIN 1787-73

Acabado:
ESTAÑADO, TINNED, ETAMÉ

CABLE		Ø	Ø	Ø	L	HERRAMIENTA	REF.	CABLE		Ø	Ø	Ø	L	HERRAMIENTA	REF.
Norm.	Flex.	A	C	D		Tool / Outil		Norm.	Flex.	A	C	D		Tool / Outil	
16	10	6	12	6,5	22,8	T50 y TP5	60 - 60	50	35	10	18,5	6,5	36,25	T50, T95, PHC	100 - 60
16	10	6	14,5	8,2	24,4		60 - 80	50	35	10	18,5	8,5	36,25		100 - 80
16	10	6	16	10,5	27,25		60 - 100	50	35	10	18,5	10,5	36,25		100 - 100
16	10	6	18,5	12,5	33,25		60 - 120	50	35	10	20,5	12,5	39,25		100 - 120
25	16	7	14,5	6,5	26,75	T50 y T95	70 - 65	50	35	10	20,5	13	39,25		100 - 130
25	16	7	14,5	8,5	26,75		70 - 80	50	35	10	24	14,5	44,75	100 - 140	
25	16	7	16	10,5	29,75		70 - 100	50	35	10	24	16,5	44,75	100 - 160	
25	16	7	18,5	12,5	34		70 - 120	70		11,5	20,5	8,5	39	T95, T150, PHC	115 - 80
35	25	8	15	6,5	29,5		80 - 60	70		11,5	20,5	10,5	39		115 - 100
35	25	8	15	8,5	29,5		80 - 80	80 - 100	70		11,5	20,5	13	41	115 - 130
35	25	8	16,5	10,5	31,25		80 - 100	80 - 120	70		11,5	24	14,5	46,25	115 - 140
35	25	8	18,5	12,5	34		80 - 120	90 - 60	70		11,5	24	16,5	46,25	115 - 160
40		9	16,5	6,5	33		90 - 60	90 - 80	70	50	12	22	8,5	41	120 - 80
40		9	16,5	8,5	33		90 - 80	90 - 100	70	50	12	22	10,5	41	120 - 100
40		9	18,7	10,5	34,5	90 - 100	90 - 120								
40		9	18,7	12,5	34,5	90 - 120									

TERMINALES TUBULARES EN COBRE A COMPRESIÓN

Apriete por punzonado

CONEXIONES ELECTRICAS, S.A.



Commercial cable lugs - Crimping by punching
Cosses de cuivre - Sertissage per poinçonnage

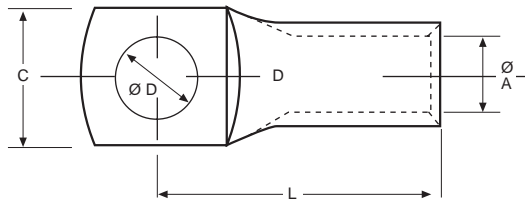

Material:

SECU S/DIN 1787-73

Acabado:

ESTAÑADO, TINNED, ETAMÉ

CABLE		Ø	Ø	Ø	L	HERRAMIENTA	REF.	CABLE		Ø	Ø	Ø	L	HERRAMIENTA	REF.	
Norm.	Flex.	A	C	D		Tool / Outil		Norm.	Flex.	A	C	D		Tool / Outil		
70	50	12	22,3	13	41	T95, T150, PHC	120 - 130	120	95	15,5	28	13	53	T150, PHC, HM5	155 - 130	
70	50	12	24	14,5	46,25		120 - 140	120	95	15,5	28	14,5	53		155 - 140	
70	50	12	24	16,5	46,25		120 - 160	120	95	15,5	28	16,5	53		155 - 160	
95	70	13,5	24	8,5	45,25		130 - 80	150	120	17	30,5	10,5	57		170 - 100	
95	70	13,5	24	10,5	45,25		130 - 100	150	120	17	30,5	13,5	57		170 - 130	
95	70	13,5	25	13,2	46,75		130 - 130	150	120	17	30,5	14,5	57		170 - 140	
95	70	13,5	25	14,5	46,75		130 - 140	150	120	17	30,5	16,5	57		170 - 160	
95	70	13,5	25	16,5	46,75		130 - 160	185	150	19	33,5	12,5	59,5		PHC, PHH, HM5	185 - 120
100		14	25	8,5	49		140 - 80	185	150	19	33,5	14,5	59,5			185 - 140
100		14	25	19,5	49		140 - 100	185	150	19	33,5	16,5	59,5			185 - 160
100		14	25	13,5	52,5		140 - 130	240	185	21	37	12,5	67			210 - 120
100		14	25	14,5	52,5		140 - 140	240	185	21	37	14,5	67			210 - 140
100		14	25	16,5	52,5		140 - 160	240	185	21	37	16,5	67			210 - 160
120	95	15,5	28	8,5	51,25		T150, PHC, HM5	155 - 80	240	185	21	37	20,5		67	210 - 200
120	95	15,5	28	10,5	51,25	155 - 100										

TERMINALES TUBULARES EN COBRE A COMPRESIÓN

Apriete por punzonado

CONEXIONES ELECTRICAS, S.A.



Commercial cable lugs - Crimping by punching
Cosses de cuivre - Sertissage per poinçonnage

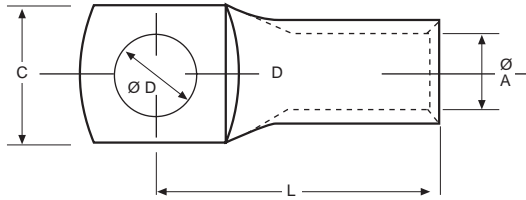

Material:
SECU S/DIN 1787-73
Acabado:
ESTAÑADO, TINNED,
ETAMÉ

CABLE		Ø A	Ø C	Ø D	L	HERRAMIENTA Tool / Outil	REF.
Norm.	Flex.						
300	240	23	41	18,2	80,5	PHC, PHH	230 - 180
300	240	23	41	20,5	80,5		230 - 200
400	300	27	48	18,2	93	PHP, U20	270 - 180
400	300	27	48	20,5	93		270 - 200
500	400	30	53	18,5	107,2		290 - 180
500	400	30	53	20,5	107,2		290 - 200
600	500	34	59	18,5	124		340 - 180
600	500	34	59	18,5	124		340 - 200

TERMINALES TUBULARES COBRE PALA ESTRECHA

CONEXIONES ELECTRICAS, S.A.



Copper narrow Palm Cable lugs
Cosses en cuivre, Pelle Etroit

Material:
SECU S/DIN 1787-73
Acabado: ESTAÑADO - TINNED

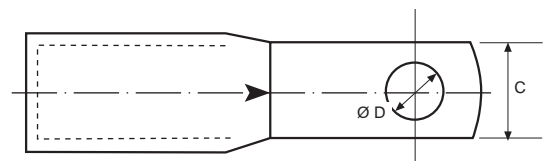
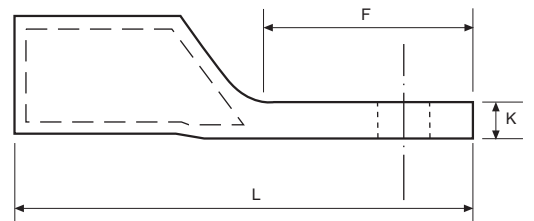

CABLE mm ²		C	D*	F	L	K	HERRAMIENTA Tool / Outil	REF.
Norm.	Flex.							
50	35	11	M 5	19	49	4	T 50 - T 95	100-11
70	50	13	M 6	21	53	4	T 95 - T 150	115 - 13
95	70	15	M 8	23	60	4		130 - 15
120	95	17	M 10	28	70	5	T 150 - PHC - HM5	155 - 17
150	120	19	M 10	30	76	6		170 - 19
185	150	22	M 12	30	77	6	PHC - HM5	190 - 22
240	185	22	M 12	30	85	8		210 - 22

* D. Máximo

TERMINAL TUBULAR COBRE EN ESCUADRA

CONEXIONES ELECTRICAS, S.A.



90° palm copper lug
Cosses de pelle equerre, cuivre

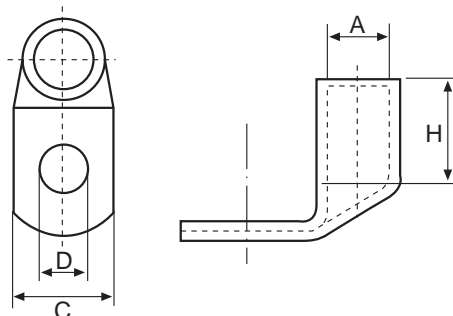

Material:
SECU S/DIN 1787-73
Acabado: ESTAÑADO-TINNED

CABLE mm ²		A	D	C	H	HERRAMIENTA DE APRIETE Tool / Outil	REF.	
Norm.	Flex.							
6	4	3,5	6	12	9	T50	KE 6- 6	
6	4	—	8	15	10		KE 6- 8	
10	6	4,5	6	12	10		KE 10- 6	
10	6	—	8	15	10		KE 10- 8	
16	10	5,5	6	12	13		KE 16- 6	
16	10	—	8	15	13		KE 16- 8	
25	16	7	8	16	15		KE 25- 8	
25	16	—	10	18	15		KE 25-10	
35	25	8,5	8	17	17		KE 35- 8	
35	25	—	10	19	17		KE 35-10	
50	35	10	10	20	20		KE 50-10	
—	—	—	13	23	20		KE 50-12	
70	50	12	10	24	21		T95	KE 70-10
—	—	—	13	24	21			KE 70-12
95	70	13,5	10	26	25	KE 95-10		
—	—	—	13	26	25	KE 95-12		
120	95	15	10	28	26	KE 120-10		
120	95	15	13	28	30	PHC		KE 120-13
150	120	16,5	10	31	30		KE 150-10	
—	—	—	13	31	30		KE 150-12	
185	150	19	13	35	30		KE 185-12	
240	185	21	16	37	35		KE 240-16	

DIN 46235 TERMINALES TUBULARES DE COBRE

CONEXIONES ELECTRICAS, S.A.



Tubular copper compression lugs for hexagonal pressing DIN 46235
Cosses tubulaires en cuivre DIN 46235

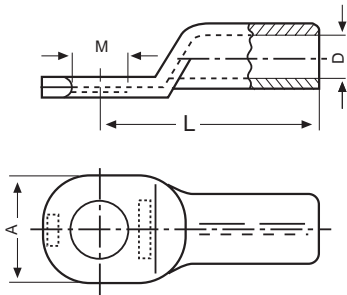

Material:
SE-Cu Estañado
DIN 1787-73
Tin Plated

CABLE mm ²	TORNILLO Bolt M	L	A	D Ø	MATRIZ HEXAG. Die. size	NÚMERO DE APRIETES Number of crimps		REF.
						TENAZA Handtool	Hydraul.	
6	5	24	8,5	3,8	6	1		D. 6-5
10	6	27	9	4,5	6	1		D. 10-6
16	6	36	13	5,5	8	2		D. 16-6
	8		16-8					
	10		16-10					
25	6	38	14	7	10	2		D. 25-6
	8		25-8					
	10		25-10					
	12		25-12					
35	8	42	17	8,2	12	2		D. 35-8
	10		35-10					
	12		35-12					
50	8	52	20	10	14	3		D. 50-8
	10		50-10					
	12		50-12					
	16		50-16					
70	10	55	24	11,5	16	3		D. 70-10
	12		70-12					
	16		70-16					
95	10	65	28	13,5	18	4	2	D. 95-10
	12		95-12					
	16		95-16					
120	12	70	31	15,5	20	4	2	D.120-12
	16		120-16					
150	12	78	34	17	22	4	2	D.150-12
	16		150-16					
185	16	82	37	19	25		2	D. 185-16
	20		185-20					
240	16	92	42	21,5	28		2	D. 240-16
	20		240-20					

TERMINAL TUBULAR DE COBRE ESTAÑADO NF

CONEXIONES ELECTRICAS, S.A.



NF Tinned copper lug
Cosses de cuivre étamé NF

LAS MEDIDAS SON CONFORME A LA NORMA
NF C20-130

Measurement according to French Standard
NF C20-130

Les mesures sont suivant la Norme
NF C20-130

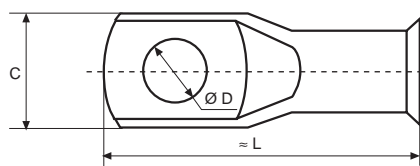
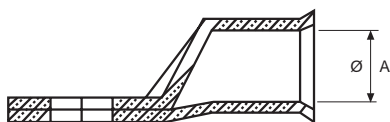

Material:
SECU S/ DIN 1787-73

CABLE	Ø A	Ø D	C	L	HERRAMIENTA Tool / Outil	REF.
16	5,5	6,5	13	42	T50	NF 16- 6
—	—	8,5	17	42		NF 16- 8
25	6,8	8,5	17	43		NF 25- 8
—	—	10,5	17	43		NF 25-10
35	8	8,5	17	45		NF 35- 8
—	—	10,5	17	45		NF 35-10
50	9,4	10,5	18	51		NF 50-10
—	—	13	19	51		NF 50-12
70	11,2	10,5	21	55		NF 70-10
—	—	13	22	55		NF 70-12
95	13,3	13	24	66	T95	NF 95-12
—	—	16,5	24	66		NF 95-16
120	14,7	13	28	71		NF 120-12
—	—	16,5	28	71		NF 120-16
150	16,4	14,5	31	79	PHC	NF 150-14
—	—	16,5	31	79		NF 150-16
185	18,2	16,5	33	83		NF 185-16
240	20,8	16,5	37	92		NF 240-16
300	23	16,5	41	102		NF 300-16

TERMINALES TC Cu MACIZO

CONEXIONES ELECTRICAS, S.A.



Solid Cu cable Lugs
Cosses de cuivre massif

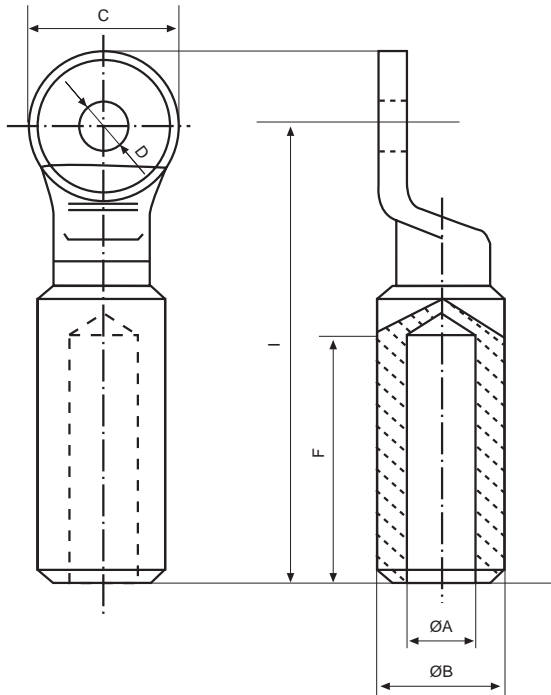

Material:
ECU DIN 1787-73



SECCION mm ²	Ø A	Ø B	Ø C	Ø D	F	I	REF.
16	5,5	12,2	26	13	30	71	TC16
25	7	12,2	26	13	30	71	TC25
35	8	12,2	26	13	30	71	TC35
50	9,5	12,2	26	13	35	71	TC50
70	11,5	21	26	13	35	71	TC70
95	13	21	26	13	35	77	TC95
120	15	21	30	13	45	97	TC120
150	16,5	21	30	13	45	97	TC150
185	18,5	26,2	36	13	45	101	TC185
240	21	26,2	36	13	50	101	TC240
300	23	28	42	16,5	50	132	TC300
400	26	32	42	16,5	55	132	TC400

TERMINALES CHAPA COBRE C - 4

CONEXIONES ELECTRICAS, S.A.



Serie S con la junta sin soldar - Serie J con la junta soldada

Cable Lugs E Cu sheet tinned - S pieces with joint no welded - J pieces with joint welded, brazed

Cosses par sertissage

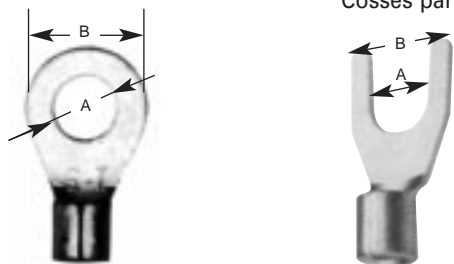

CABLE mm ²	A	B	REFERENCIA
HASTA 0,5	3	6	S 5-35
	4		S 5-45
HASTA 1,5	3	6	S 10-35
	3,5	6	S 10-37
	3	5,5	S 10-35 H
	4	8,5	S 10-45
	4	6,5	S 10-45 H
	5	8,5	S 10-55
1,5 A 2,5	5	8,5	S 10-55 H
	3	5,5	S 25-35
	3	6,5	S 25-35 H
	4	8,5	S 25-45
	4	6,8	S 25-45 H
	5	8,5	S 25-55
4 A 6	5	8,5	S 25-55 H
	6	12	S 25-60
	8	12	S 25-80
	4	8	S 30-45
	4	8	S 30-45 H
	5	10	S 30-55
6,1 A 10	5	10	S 30-55 H
	6	12	S 30-65
	6	12	S 30-65 H
	8	14	S 30-85
10,1 A 16	10	18	S 30-100 H
	5	8	S 40-55
	6	14,5	S 40-65
16,1 A 25	8	14,5	S 40-80
	8	14,5	S 50-55
	6	14,5	S 50-60
	8	14,5	S 50-80
	8	18	S 70-80
	10	18	S 70-100

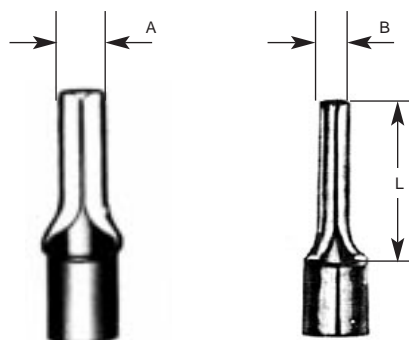

CABLE mm ²	A	B	L	REFERENCIA	
				Con junta sin soldar	Con junta soldada
1,5	∅ 1,9	0,8	11	SC 15	JC 15
1,5	2,5	0,8	11	SCP 15	JCP 15
2,5	∅ 1,9	0,8	11	SC 26	JC 26
2,5	2,5	0,8	11	SCP 26	JCP 26
6	∅ 2,9	1	11	SC 60	JC 60
6	4	1	11	SCP 60	JCP 60
10	4,5	2	13	SC 100	JC 100
16	6	2,4	14	SC 160	JC 160
25	7	3	16	SC 250	JC 250
35	8	3	20	SC 350	JC 350
50	9,5	4	20	SC 500	JC 500
70	11	4	23		JC 700
95	12,5	5	23		JC 950

TERMINAL COBRE ESTAÑADO PALA LARGA 2 AGUJEROS

CONEXIONES ELECTRICAS, S.A.



Copper lug, Long Palm, 2 holes

Cosses de cuivre, pelle long, 2 trous

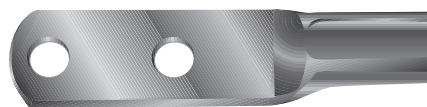
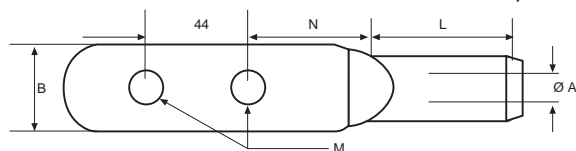

SECCION mm ²	A	M	N	B	L	REF.
25	7	8 ó 10	16	16	18	25-8-2-44
35	8	8 ó 10	17	17	23	35-8-2-44
50	10	10 ó 12	20	20	26	50-10-2-44
70	11,5	10 ó 12	22	21	32	70-10-2-44
95	13,5	12 ó 16	27	25	35	95-12-2-44
120	15,5	12 ó 16	32	31	41	150-12-2-44
150	17	12 ó 16	32	31	41	150-12-2-44
185	19	12 ó 16	34	33	44	185-12-2-44
240	21	14 ó 16	38	37	46	240-14-2-44
300	23	16 ó 18	42	41	48	300-16-2-44

TERMINALES DIN 46 234

CONEXIONES ELECTRICAS, S.A.



DIN 46 234 copper Lugs
Cosses cuivre DIN 46 234

Material:
ECU
ESTAÑADO TINNED

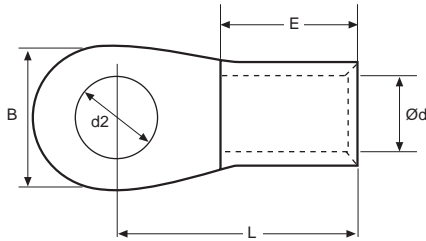

CABLE mm ²	DIMENSIONES / Dimensions					HERRAMIENTA Tool / Outil	REF.	CABLE mm ²	DIMENSIONES / Dimensions					HERRAMIENTA Tool / Outil	REF.
	d2	B	l	E	d				d2	B	l	E	d		
0,5-1,5	3,2	6,0	11,0	5,0	1,6	TP 3	J 1-3	25-35	6,5	15,0	26,0	12,0	9,0	T50	J 35-6
0,5-1,5	3,7	6,0	11,0	5,0	1,6		J 1-3,5	25-35	8,4	16,0	26,0	12,0	9,0		J 35-8
0,5-1,5	4,3	8,0	12,0	5,0	1,6		J 1-4	25-35	10,5	18,0	27,0	12,0	9,0		J 35-10
0,5-1,5	5,3	10,0	13,0	5,0	1,6		J 1-5	25-35	13,0	22,0	31,0	12,0	9,0		J 35-12
1,5-2,5	3,2	6,0	11,0	5,0	2,3		J 2-3	25-35	17,0	28,0	36,0	12,0	9,0		J 35-16
1,5-2,5	3,7	6,0	11,0	5,0	2,3		J 2-3,5	35-50	6,5	18,0	34,0	16,0	11,0		J 50-6
1,5-2,5	4,3	8,0	12,0	5,0	2,3		J 2-4	35-50	8,4	18,0	34,0	16,0	11,0		J 50-8
1,5-2,5	5,3	10,0	14,0	5,0	2,3		J 2-5	35-50	10,5	18,0	34,0	16,0	11,0		J 50-10
1,5-2,5	6,5	11,0	16,0	5,0	2,3		J 2-6	35-50	13,0	22,0	36,0	16,0	11,0		J 50-12
1,5-2,5	8,4	14,0	17,0	5,0	2,3		J 2-8	35-50	17,0	28,0	40,0	16,0	11,0		J 50-16
2,5-6,0	4,3	8,0	14,0	6,0	3,6	J 6-4	50-70	8,4	22,0	38,0	18,0	13,0	T 95	J 70-8	
2,5-6,0	5,3	10,0	15,0	6,0	3,6	J 6-5	50-70	10,5	22,0	38,0	18,0	13,0		J 70-10	
2,5-6,0	6,5	11,0	16,0	6,0	3,6	J 6-6	50-70	13,0	22,0	38,0	18,0	13,0		J 70-12	
2,5-6,0	8,4	14,0	19,0	6,0	3,6	J 6-8	50-70	17,0	28,0	42,0	18,0	13,0		J 70-16	
2,5-6,0	10,5	18,0	21,0	6,0	3,6	J 6-10	70-95	8,4	24,0	42,0	20,0	15,0		J 95-8	
6-10	5,3	10,0	16,0	8,0	4,5	J 10-5	70-95	10,5	24,0	42,0	20,0	15,0		J 95-10	
6-10	6,5	11,0	17,0	8,0	4,5	J 10-6	70-95	13,0	24,0	42,0	20,0	15,0	J 95-12		
6-10	8,4	14,0	20,0	8,0	4,5	J 10-8	70-95	17,0	28,0	44,0	20,0	15,0	J 95-16		
6-10	10,5	18,0	21,0	8,0	4,5	J 10-10	95-120	10,5	24,0	44,0	22,0	16,5	PHC	J 120-10	
6-10	13,0	22,0	23,0	8,0	4,5	J 12-10	95-120	13,0	24,0	44,0	22,0	16,5		J 120-12	
10-16	6,5	11,0	20,0	10,0	5,8	TP 5	J 16-6	95-120	17,0	28,0	48,0	22,0		16,5	J 120-16
10-16	8,4	14,0	22,0	10,0	5,8		J 16-8	120-150	10,5	30,0	50,0	24,0		19,0	J 150-10
10-16	10,5	18,0	24,0	10,0	5,8		J 16-10	120-150	13,0	30,0	50,0	24,0		19,0	J 150-12
10-16	13,0	22,0	26,0	10,0	5,8		J 16-12	120-150	17,0	30,0	50,0	24,0		19,0	J 150-16
16-25	6,5	12,0	25,0	11,0	7,5	T 50	J 25-6	150-185	10,5	36,0	50,0	28,0	21,0	J 185-10	
16-25	8,4	16,0	25,0	11,0	7,5		J 25-8	150-185	13,0	36,0	50,0	28,0	21,0	J 185-12	
16-25	10,5	18,0	26,0	11,0	7,5		J 25-10	150-185	17,0	36,0	50,0	28,0	21,0	J 185-16	
16-25	13,0	22,0	31,0	11,0	7,5		J 25-12	185-240	10,5	38,0	56,0	32,0	23,5	J 240-10	
16-25	17,0	28,0	35,0	11,0	7,5		J 25-16	185-240	13,0	38,0	56,0	32,0	23,5	J 240-12	
									185-240	17,0	38,0	56,0	32,0	23,5	J 240-16